

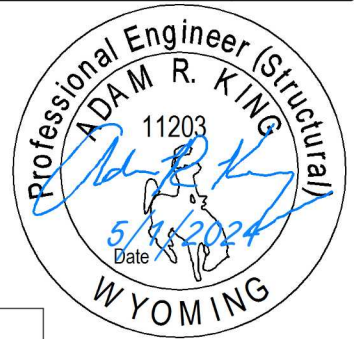

# LARAMIE COUNTY FOUNDATION STANDARDS

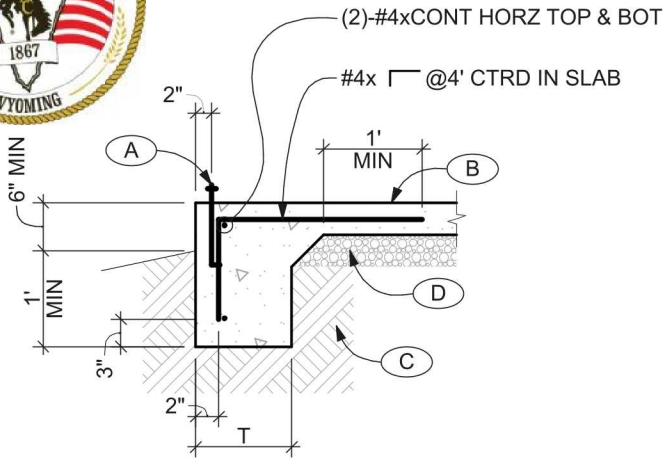

valid until 5/1/2025



ROOF CLEAR SPAN 'W' vs. WALL WIDTH 'T'	
W <sub>R</sub>	T
W <sub>R</sub> ≤ 28'	8"
28' < W <sub>R</sub> ≤ 34'	10"

**TYPICAL FOR DETAILS 1 & 2**  
1) Cultured stone no more than 4' tall is allowed. Real brick/stone veneer not allowed

## 1 SHALLOW MONOLITHIC FND

-Unattached, single-story, wood-framed accessory building 600 sqft OR LESS (e.g. agricultural/storage building, detached garage)

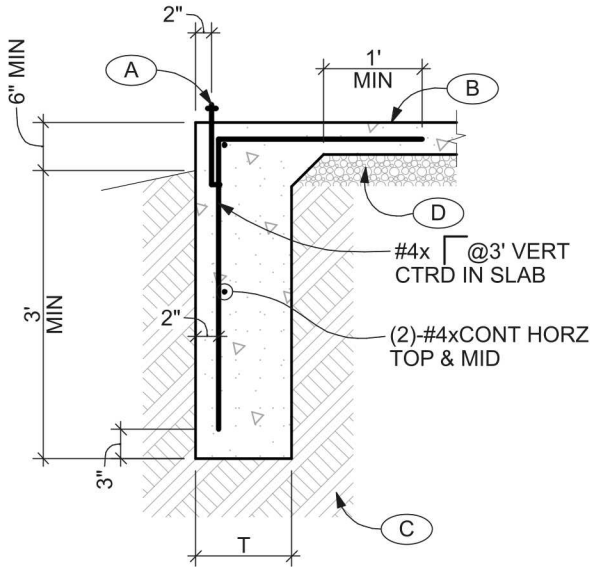

## 2 MONOLITHIC TRENCH WALL FND

-Attached, single-story, wood-framed garage or room addition  
-Unattached, single-story, wood-framed accessory building GREATER THAN 600 sqft.

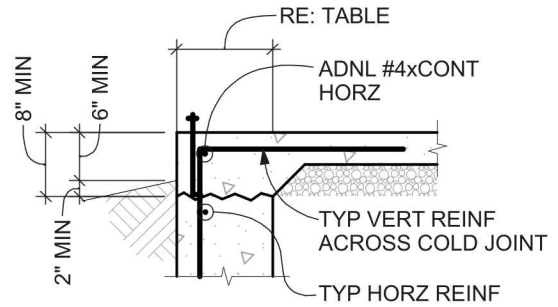

SEPARATE POUR - OPTION A

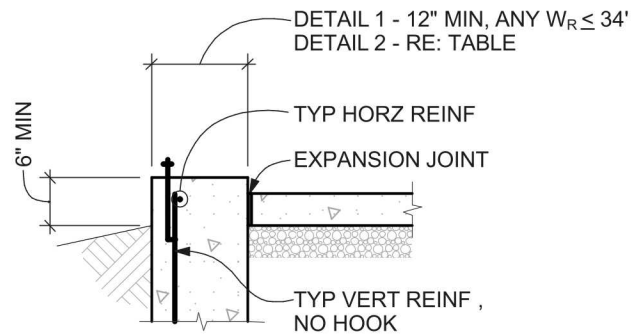

SEPARATE POUR - OPTION B

### KEYNOTES

- A - 1/2"φ anchor bolt @6' with 7" min embedment. Provide standard nut & washer (1 1/16" OD x 0.097"-0.177" thick). Minimum (2) per plate section and within 12" min of plate section ends.
- B - 3 1/2" thick minimum slab-on-ground. Provide control joints (1/8" wide x 1" deep) at no more than 10' spacing w/ a maximum aspect ratio of 1.5-to-1. Reinforcement is not required; however, for additional crack control use 6x6 W2.4xW2.4 welded wire fabric or fiber reinforcement.
- C - Undisturbed natural subgrade, free of debris, organics, expansive clay, excessive moisture, and frost. Fill used for embankments shall be compacted to 90% minimum (ASTM D 698).
- D - Slabs-on-ground may be continuously supported on undisturbed natural soil or with fill free of debris, organics, clay, excessive moisture, and frost and compacted to provide uniform support of the slab. Fill depths shall not exceed 24" for clean sand or gravel or 8" for site soils. Scarified and compacted subgrade soils or fill beneath foundations and slabs shall be compacted to 95% minimum.

### LIMITATIONS

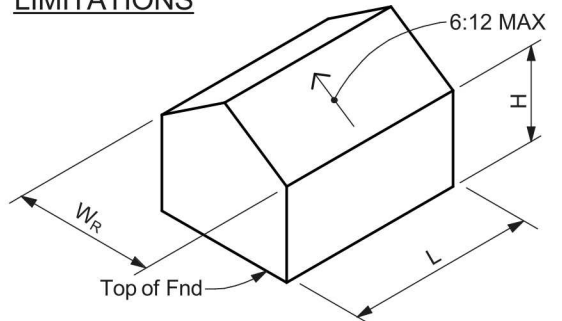

-Max Roof Clear Span, W <sub>R</sub>	See Table
-Max aspect ratio (L/W <sub>R</sub> or W <sub>R</sub> /L)	1.5
-Max Eave Height, H	10'



# LARAMIE COUNTY FOUNDATION STANDARDS

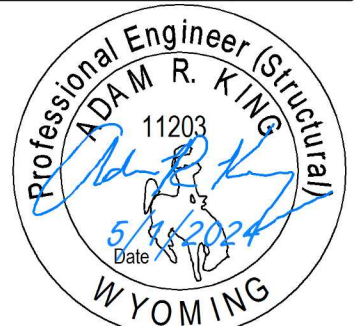

valid until 5/1/2025

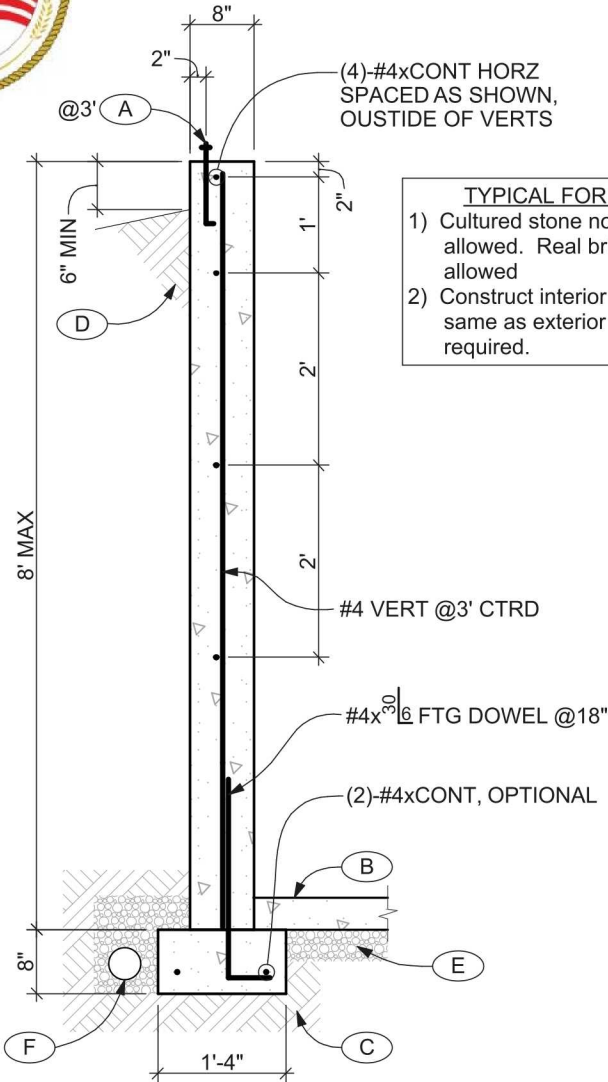

**TYPICAL FOR DETAILS 3 & 4**

- 1) Cultured stone no more than 4' tall is allowed. Real brick/stone veneer not allowed
- 2) Construct interior bearing wall footing same as exterior footing, rebar is required.

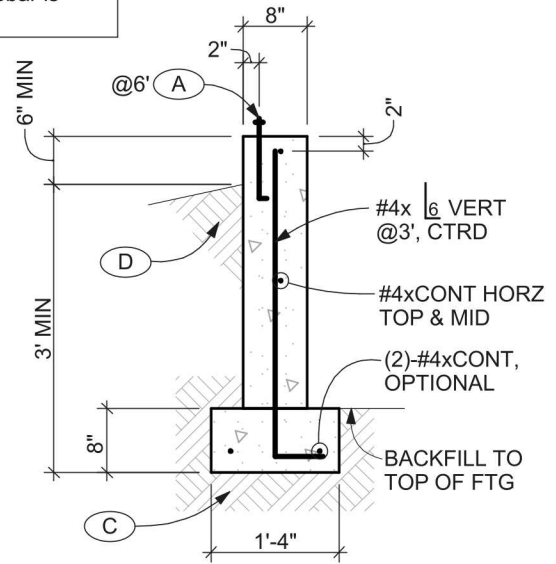

## 4 CRAWL SPACE FND WALL

-One or two story, wood-framed room addition

## 3 BASEMENT FND WALL

-One or two story, wood-framed room addition

### KEYNOTES

- A - 1/2"φ anchor bolt with 7" min embedment. Provide standard nut & washer (1 1/16"OD x 0.097"-0.177" thick). Minimum (2) per plate section and within 12" min of plate section ends.
- B - 3 1/2" thick minimum slab-on-ground. Provide control joints (1/8" wide x 1" deep) at no more than 10' spacing w/ a maximum aspect ratio of 1.5-to-1. Reinforcement is not required; however, for additional crack control use 6x6 W2.4xW2.4 welded wire fabric or fiber reinforcement.
- C - Undisturbed natural subgrade or structural fill free of debris, organics, expansive clay, excessive moisture, and frost. Structural fill beneath footings and slabs shall be placed in horizontal lifts not exceeding 8" in loose thickness. Structural fill and scarified subgrade soils shall be compacted to 95% minimum (ASTM D 698).
- D - Backfill and embankments shall be placed in horizontal lifts not exceeding 24" in loose thickness and compacted to 90% minimum. Compaction shall be performed cautiously so as not to damage foundation walls.
- E - Slabs-on-ground in below-grade habitable areas shall be continuously supported on a 4" thick minimum base course consisting of clean graded sand, gravel, crushed stone, or crushed blast-furnace slag passing a 2" sieve on prepared subgrade, and shall be compacted to 95% minimum.
- F - Perimeter drain per IRC R405.1, unless exempted by engineer or building official.

### LIMITATIONS

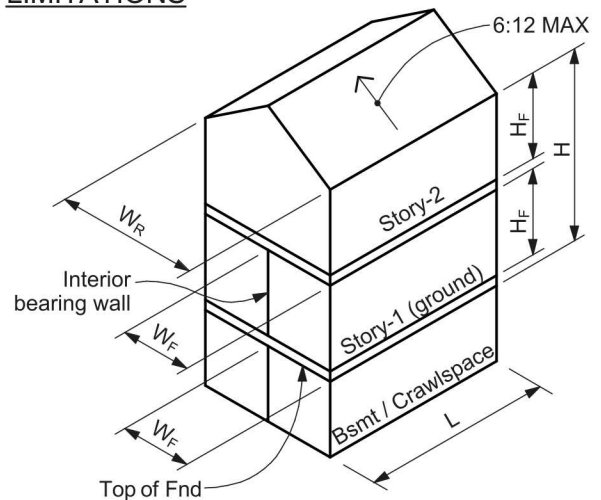

	DTL 3	DTL 4	
LIMITATION/ No. of Stories	1 or 2	1	2
-Max Roof Clear Span, $W_R$	20'	32'	24'
-Max Floor Span, $W_F$	12'	18'	14'
-Max L	20'	N/A	N/A
-Max aspect ratio ( $L/W_R$ or $W_R/L$ )	1.5	1.5	1.5
-Max Floor to Ceiling, $H_F$	9'	10'	9'
-Max Eave Height, H	20'	11'	20'





# LARAMIE COUNTY FOUNDATION STANDARDS

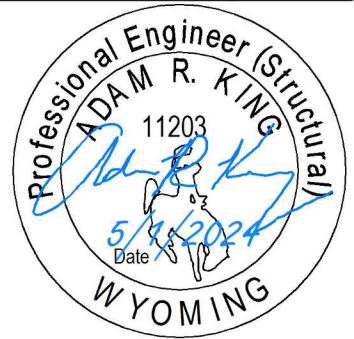

valid until 5/1/2025

- 1) Cultured stone no more than 4' tall is allowed. Real brick/stone veneer not allowed
- 2) Construct interior bearing wall footing same as exterior footing, rebar is required

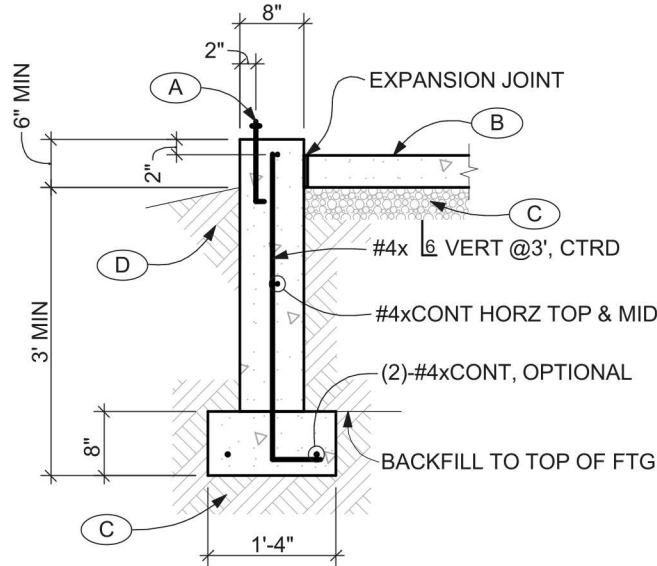

## 5 STEM WALL FOUNDATION

-One or two story, wood-framed garage or room addition or detached building

### KEYNOTES

- A - 1/2"  $\phi$  anchor bolt with 7" min embedment @ 6'. Provide standard nut & washer (1 1/16" OD x 0.097"-0.177" thick). Minimum (2) per plate section and within 12" min of plate section ends.
- B - 3 1/2" thick minimum slab-on-ground. Provide control joints (1/8" wide x 1" deep) at no more than 10' spacing w/ a maximum aspect ratio of 1.5-to-1. Reinforcement is not required; however, for additional crack control use 6x6 W2.4xW2.4 welded wire fabric or fiber reinforcement.
- C - Undisturbed natural subgrade or structural fill free of debris, organics, expansive clay, excessive moisture, and frost. Structural fill beneath footings and slabs shall be placed in horizontal lifts not exceeding 8" in loose thickness. Structural fill and scarified subgrade soils shall be compacted to 95% minimum (ASTM D 698).
- D - Backfill and embankments shall be placed in horizontal lifts not exceeding 24" in loose thickness and compacted to 90% minimum. Compaction shall be performed cautiously so as not to damage foundation walls.

### LIMITATIONS

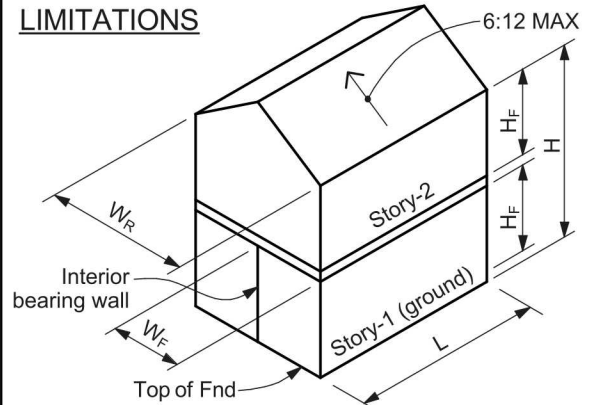

LIMITATION	No. of Stories	
	1	2
-Max Roof Clear Span, $W_R$	40'	32'
-Max Floor Span, $W_F$	N/A	18'
-Max aspect ratio ( $L/W_R$ or $W_R/L$ )	1.5	1.5
-Max Floor to Ceiling, $H_F$	10'	9'
-Max Eave Height, H	10'	19'



# LARAMIE COUNTY FOUNDATION STANDARDS

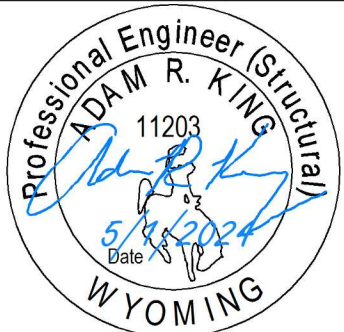

valid until 5/1/2025

L1	@
6'	24"
8'	18"
10'	14"
12'	12"
14'	10"
16'	9"

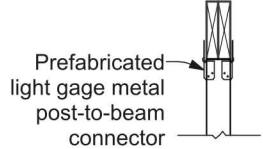
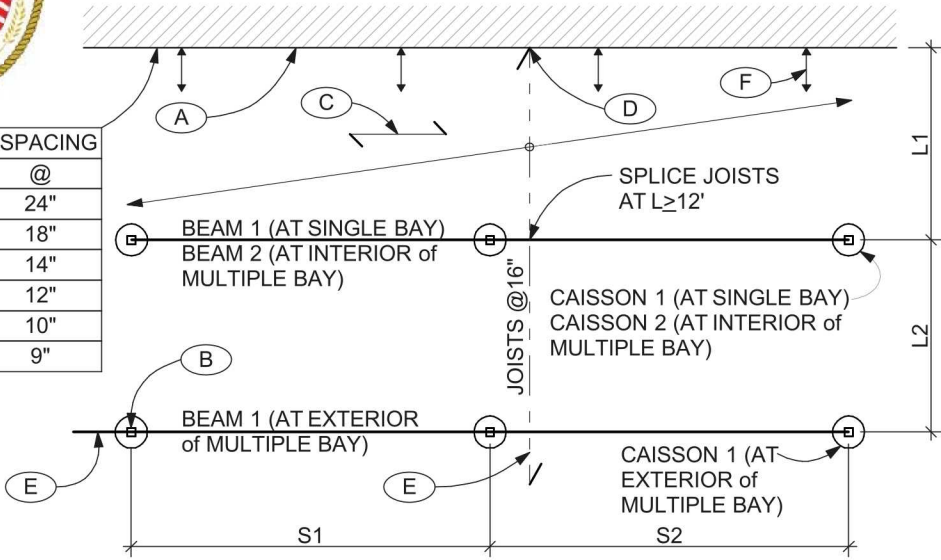

AT ANY POST & ANY BEAM

		JOIST LENGTH (max of L1, L2...,) FT				
		8	10	12	14	16
POST SPACING (max of S1, S2...,) FT	6	J: 2x6 B1: (2)-2x8 C1: 12"φ B2: (2)-2x10 C2: 16"φ	J: 2x8 B1: (2)-2x8 C1: 12"φ B2: (2)-2x10 C2: 18"φ	J: 2x8* B1: (2)-2x10 C1: 14"φ B2: (2)-2x10 C2: 18"φ	J: 2x10* B1: (2)-2x10 C1: 14"φ B2: (2)-2x12 C2: 20"φ	J: 2x12* B1: (2)-2x10 C1: 16"φ B2: (2)-2x12 C2: 22"φ
	8	J: 2x6 B1: (2)-2x10 C1: 12"φ B2: (2)-2x12 C2: 18"φ	J: 2x8 B1: (2)-2x10 C1: 14"φ B2: (2)-2x12 C2: 20"φ	J: 2x8* B1: (2)-2x12 C1: 16"φ B2: (3)-2x12 C2: 22"φ	J: 2x10* B1: (3)-2x10 C1: 16"φ B2: (3)-2x12 C2: 24"φ	NOT ALLOWED
	10	J: 2x6 B1: (2)-2x12 C1: 14"φ B2: (3)-2x12 C2: 20"φ	J: 2x8 B1: (3)-2x10 C1: 16"φ B2: (3)-2x12 C2: 22"φ	J: 2x8* B1: (3)-2x12 C1: 18"φ B2: Not Allowed C2: Not Allowed	NOT ALLOWED	NOT ALLOWED

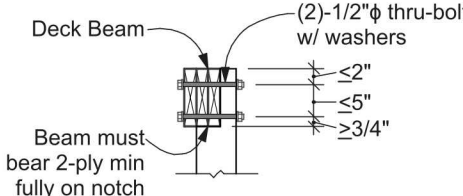
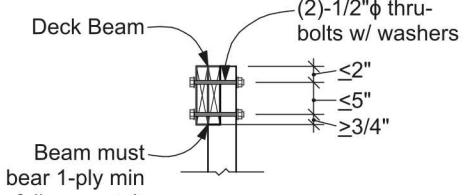

**TYPICAL NOTES:**

- 1) J = JOIST size; B1 = BEAM 1 size; C1 = CAISSON 1 size; B2 = BEAM 2 size; C2 = CAISSON 2 size
- 2) Framing to be pressure preservative treated Southern Pine #2, or better
- 3) All fasteners to be Type 304 or 316 stainless steel.
- 4) At multiple span joists or beams with unequal spans, the shorter span must be at least 75% of the longer span.
- 5) Double 2x beams may be substituted with single 4x of equal depth.
- 6) \*Indicates multiple single spans, do not make joists continuous over beam

**KEYNOTES:**

- (A) -Support joists at house with ledger to match joist, but not less than 2x8, attached directly to house sheathing and rimboard with 1/2"φ x 3 1/2" lag screw spaced per Table. Presence of a 1" engineered wood or 1 1/2" sawn lumber rimboard must be verified.
- (B) -4x4 post for up to 9' height if beam is centered, or 8' if beam is notched-in; or 6x6 post for up to 14' height. Post size shall be no less than width of beam (e.g. 6x6 required for 3-ply beam).
- (C) -2x flat deck planks, perpendicular to joists. Adjust joist spacing as required if using other product.
- (D) -Face-mount joists to end supports w/ Simpson LU or LUS hanger, or equal.
- (E) -Joists may cantilever 12" max, Beams may cantilever 16" max
- (F) -Lateral connections per IRC Figure R507.2.3(2)

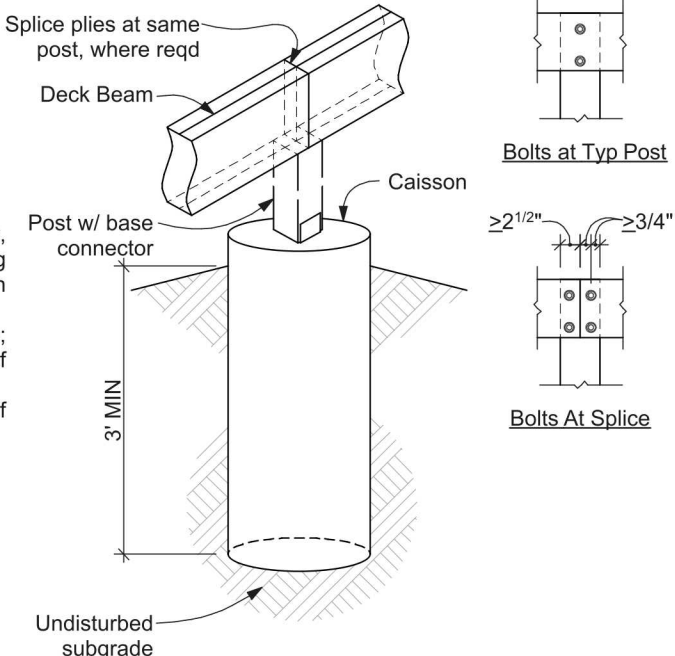





## GENERAL NOTES

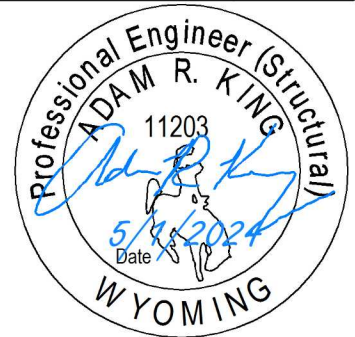

valid until 5/1/2025

### CONCRETE MIX DESIGN:

COMPONENT	28-DAY COMPRESSIVE STRENGTH, f <sub>c</sub>	AIR CONTENT	MAX CHLORIDE ION CONTENT (a)
Interior basement walls, footings and other concrete not exposed to weather	2500 PSI	NR	1.00%
Basement slabs and interior slabs-on-ground, except garage floor slabs	2500 PSI	NR	1.00%
Exterior foundation walls, monolithic floor slabs (no steel trowel finish), piers and other vertical concrete exposed to weather	3000 PSI	5%-7%	0.30%
Porches, carport slabs, and steps exposed to weather, and garage floor slabs - without steel trowel finish	3500 PSI	5%-7%	0.15%
Monolithic floor slabs and garage floor slabs - with steel trowel finish	4000 PSI	3%-7%	0.15%

### FOOTNOTES:

(a) BY WEIGHT OF CEMENTITIOUS MATERIAL

### OTHER CONCRETE MIX REQUIREMENTS:

1. WATER-SOLUBLE SULFATE (SO<sub>4</sub>) POTENTIAL IN SOIL IS UNKNOWN. IF SULFATES ARE ENCOUNTERED, CONTACT ENGINEER FOR ADDITIONAL REQUIREMENTS
2. PORTLAND CEMENT, TYPE I/II
3. AGGREGATE = 3/4" MAXIMUM, NORMAL-WEIGHT
4. MIX DESIGN IS NOT PROPORTIONED FOR EXPOSURE TO ELEVATED SULFATE LEVELS. CONTACT ENGINEER IF SUCH LEVELS ARE ENCOUNTERED.
5. GENERAL CONTRACTOR SHALL OBTAIN FROM THE AGGREGATE SUPPLIER LABORATORY TESTS CONTAINING DATA ON THE MINERALOGY (ASTM C 95) AND POTENTIAL REACTIVITY WITH ALKALIES. IF AGGREGATES TO BE SUPPLIED ARE CONSIDERED POTENTIALLY REACTIVE, CONCRETE MIX DESIGN SHALL INCORPORATE MEANS TO CONTROL ALKALI-SILICA REACTIONS. REFER TO "PCA-GUIDE TO SPECIFICATION FOR CONCRETE SUBJECT TO ALKALI-SILICA REACTIONS" FOR DETAILED INFORMATION.
6. ALL CONCRETE MATERIALS AND SHALL CONFORM TO ACI 332, LATEST EDITION.
7. REFER TO ACI 318, CH. 4, TABLE 4.4.2 FOR MAXIMUM PERCENT OF TOTAL CEMENTITIOUS MATERIALS.

### REINFORCEMENT:

- DEFORMED STEEL REINFORCING BARS SHALL CONFORM TO ASTM A615, ASTM A706, OR ASTM A996. THE SPECIFIED YIELD STRENGTH OF REINFORCEMENT SHALL NOT BE LESS THAN 60,000 PSI.
- WELDED WIRE REINFORCEMENT SHALL CONFORM TO ASTM A185.
- FIBER REINFORCEMENT (SYNTHETIC) SHALL CONFORM TO SECTION 4.1.1, TYPE III, OF ASTM C1116 AND ASTM C1399. FIBER REINFORCEMENT (STEEL) SHALL CONFORM TO SECTION 4.1.1, TYPE I, OF ASTM C 1116 AND ASTM A 820.
- LAP CONTINUOUS (CONT) HORIZONTAL REINFORCEMENT 18" MINIMUM AT SPLICES AND CORNERS.

### REINFORCEMENT COVER (C):

- CONCRETE CAST AGAINST EARTH: 3" (±3/8")
- CONCRETE PLACED IN FORMS AND EXPOSED TO EARTH OR WEATHER IN SERVICE: 2" (±3/8")
- CONCRETE PLACED IN FORMS AND NOT EXPOSED TO EARTH OR WEATHER IN SERVICE: 1"
- SLABS: PLACE IN MIDDLE THIRD OF SLAB THICKNESS

### ANCHORAGE:

- CAST-IN-PLACE ANCHOR BOLTS (AB): ASTM F1554 GRADE 55 WELDABLE, PLAIN, F<sub>y</sub> = 55 KSI UNLESS NOTED OTHERWISE. EMBEDDED END TO BE HEAVY HEX HEAD, L-BENT, J-BENT, OR NUTTED WITH HEAVY HEX NUT TACK WELDED. REQUIRED EMBEDMENT IS MEASURED AS THE DISTANCE FROM THE TOP OF THE HEAD, NUT, OR BEND TO THE TOP SURFACE OF MONOLITHIC CONCRETE. 1/2" MINIMUM LENGTH PAST GRIP. ANCHORS MAY BE WET-STABBED.
- POST-INSTALLED ANCHORS: MUST HAVE ICBO REPORT AVAILABLE FOR ENGINEER REVIEW IF DEEMED NECESSARY. UNLESS NOTED OTHERWISE, MINIMUM EMBEDMENT DEPTH SHALL BE EQUAL TO 10x THE BOLT DIAMETER, UNLESS NOTED OTHERWISE. PROVIDE THE FOLLOWING:
  - i. EXPANSION ANCHORS: WEDGE-TYPE IN ACCORDANCE WITH ASTM B 633. ANCHORS MUST MEET THE DESCRIPTION OF FEDERAL SPECIFICATION A-A 1923A, TYPE 4. ANCHOR TO BEAR A LENGTH IDENTIFICATION CODE THAT IS VIEWABLE AFTER INSTALLATION.
  - ii. EPOXY ANCHORS: THREADED ROD ASTM A307 SECURED WITH ADHESIVE MEETING ASTM-C-881-90, TYPES IV AND V, GRADES 2 AND 3, CLASS A, B, AND C.
  - iii. SCREW ANCHOR: SIMPSON "TITEN HD" OR APPROVED EQUAL. PROVIDE 8x ANCHOR DIAMETER FOR EMBEDMENT, 1-3/4" MIN CONCRETE EDGE DISTANCE ON ONE SIDE AND (10x ANCHOR DIAMETER) MIN CONCRETE EDGE DISTANCE ON THREE OTHER SIDES.
- ABs MAY BE REPLACED WITH POST-INSTALLED ANCHORS AT THE CONTRACTORS DISCRETION. ANCHOR DIAMETER TO MATCH AND EMBEDMENT SHALL BE PER ABOVE.

### WEATHER:

- DURING ANTICIPATED AMBIENT TEMPERATURE CONDITIONS OF 35 DEGREES FARENHEIT OR LESS, CONCRETE TEMPERATURES SHALL BE MAINTAINED ABOVE A FROZEN STATE UNTIL A CONCRETE COMPRESSIVE STRENGTH OF 500 PSI HAS BEEN REACHED. A MATURITY CURVE FROM THE CONCRETE SUPPLIER CAN BE USED. REFER TO ACI 306R FOR FURTHER INFORMATION REGARDING COLD-WEATHER CONCRETING PRACTICES.
- CONCRETE MATERIALS, REINFORCEMENT, FORMS, AND ANY EARTH WITH WHICH CONCRETE IS TO COME IN CONTACT SHALL BE FREE FROM FROST. FROZEN MATERIALS OR MATERIALS CONTAINING ICE SHALL NOT BE USED.
- DURING HOT WEATHER, PROPER ATTENTION SHALL BE GIVEN TO INGREDIENTS, PRODUCTION METHODS, HANDLING, PLACING, PROTECTION, AND CURING OF CONCRETE TO PREVENT EXCESSIVE CONCRETE TEMPERATURES OR WATER EVAPORATION THAT COULD IMPAIR REQUIRED STRENGTH OR SERVICEABILITY OF THE MEMBERS OF THE STRUCTURE. REFER TO ACI 305R FOR INFORMATION ON HOT-WEATHER CONCRETING PRACTICES.

### CODES:

- 2021 INTERNATIONAL RESIDENTIAL CODE (IRC)

### GRAVITY LOADS:

- FLOOR DEAD: 20 PSF
- FLOOR LIVE: 40 PSF
- ROOF DEAD: 20 PSF
- ROOF SNOW: 30 PSF

### WIND LOADS:

- ULTIMATE BASIC WIND SPEED (3-SEC GUST), Vult: 115 MPH
- EXPOSURE CATEGORY: C

### SEISMIC LOADS:

- SEISMIC DESIGN CATEGORY: B

### FOUNDATIONS: THE FOUNDATION WAS DESIGNED WITH THE FOLLOWING CRITERIA ASSUMING CLASS I OR II SOILS PER IRC TABLE R405.1. THE USER SHALL PROVIDE AN OPEN-HOLE REPORT PER LARAMIE COUNTY REQUIREMENTS.

- ALLOWABLE SOIL BEARING PRESSURE, BUILDINGS: 1500PSF
- ALLOWABLE SOIL BEARING PRESSURE, DECKS: 1500PSF
- LATERAL EARTH PRESSURE: 45PSF
- LATERAL BEARING: 100 PSF/FT
- LATERAL SLIDING COHESION: 130 PSF

### CLIMATE:

- WEATHERING PROBABILITY: SEVERE

### DISCLAIMER:

- THE USER OF THESE DRAWINGS SHALL RECOGNIZE THAT SERVICEABILITY REQUIREMENTS FOR RESIDENTIAL CONCRETE ALLOW FOR CRACK DEVELOPMENT AND AGREES TO NOT HOLD LARAMIE COUNTY OR THE ENGINEER LIABLE FOR REPAIR OF AESTHETIC CRACKING.
- LARAMIE COUNTY AND THE ENGINEER MAKE NO GUARANTEE THE SOILS PRESENT AT THE PROJECT SITE MEET THE ASSUMED VALUES GIVEN ABOVE.